

# Data Acquisition System



## DAQ-9600

### Expand Your Measuring Tentacles

The DAQ-9600 data acquisition system has five high-quality modules and a built-in 6 1/2 digit multimeter to provide you with an efficient and accurate data acquisition.

The system measures and converts 14 different input signals: Temperature with thermocouples, RTDs and thermistors; DC/AC voltage; 2-wire and 4-wire resistance; frequency and period; DC/AC current and capacitance; direct strain and bridge strain.

Your data acquisition is controlled by logging and observing results in a variety of display options for easier analysis. A free DAQ software assists you in controlling measurement channels for your specific test configurations from multiple data acquisition units.



DAQ – Data Logger SOFTWARE

# Data Acquisition

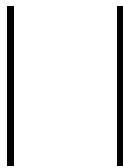

Multiplexer



Mainframe





6 1/2 digits  
Accuracy

LCD Display

USB Host

Setup

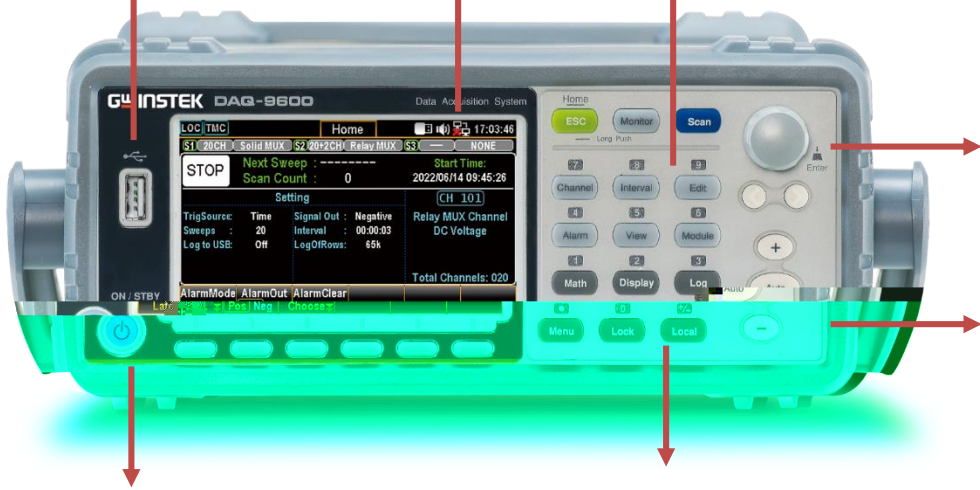

Knob

Increase  
/Decrease

Power Switch

Function Operation

3-slot  
Mainframe

Interface (Option mini GPIB)

Modules

Power Socket

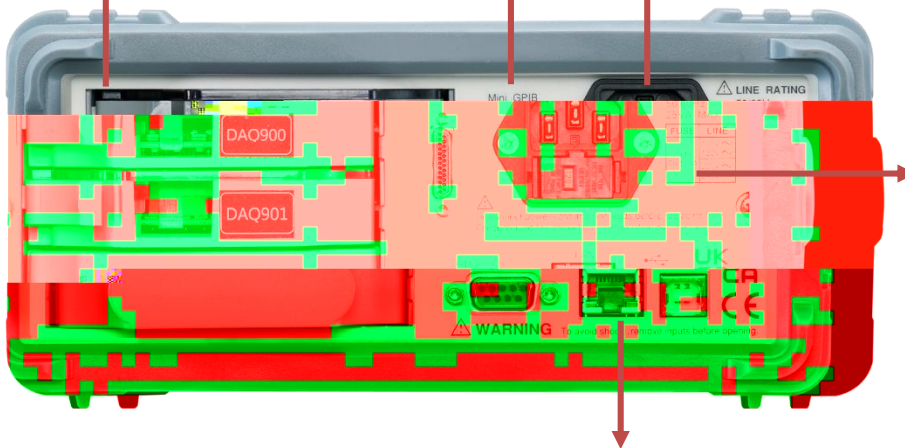

Fuse

Standard Interface  
(Digital IO/LAN/USB)

## Features (Mainframe)

- ※ Large 4.3" TFT color display
- ※ 3-slot mainframe with built-in 6 ½ digit DMM
- ※ Basic 0.0035% DCV accuracy
- ※ 5 selectable switch modules
- ※ Up to 450 channels/s scan rate
- ※ Up to 100 kilo points internal memory
- ※ Measures and converts 14 different input signals:  
Temperature with thermocouple, RTDs and thermistor; dc/ac volts; 2- and 4-wire resistance; frequency and period; dc/ac current and capacitance; direct strain and bridge strain
- ※ Commands compatible with the DAQ970A
- ※ USB storage supports copy/log data in standalone operation
- ※ Interfaces: Digit I/O, LAN, USB host/device and mini GPIB(optional)
- ※ Free PC software DAQ-Data logger, allows easy configuration and control of tests

## Features (Modules)

- |                |  |
|----------------|--|
| <b>DAQ-900</b> | <b>20-Channel Universal Multiplexer (Solid State Relay)</b>            |
| ※              | Scanning speed up to 450 channels per second                           |
| ※              | 2-wire and 4-wire scanning   |
| ※              | Built-in temperature cold junction reference                           |
| ※              | 120 V switching  |
| <b>DAQ-901</b> | <b>20+2 Channels Universal Multiplexer (Armature Relay)</b>            |
| ※              | The scanning speed can reach 80 channels per second                    |
| ※              | 2-wire and 4-wire scanning   |
| ※              | Built-in temperature cold junction reference                           |
| ※              | 300 V switching  |
| ※              | The extra 2 channels can directly measure the current (1A/per channel) |
| <b>DAQ-903</b> | <b>40-Channel Single-Ended Multiplexer</b>                             |
| ※              | The scanning speed can reach 80 channels per second                    |
| ※              | Single-wire switching is suitable for common-low applications          |
| ※              | Built-in temperature cold junction reference                           |
| <b>DAQ-904</b> | <b>4 x 8 2-Wire Matrix</b>   |
| ※              | The switching speed 3ms  |
| ※              | 32 2-wire intersections  |
| ※              | 300 V, 1A switching  |
| ※              | Up to 96 crosspoints (3 slots)   |
| <b>DAQ-909</b> | <b>8+2 Channels High Voltage High Current Multiplexer</b>              |
| ※              | The switching speed 3ms  |
| ※              | DC voltage 600V, current 2A  |
| ※              | 2-wire and 4-wire scanning   |
| ※              | Additional 2 channels can directly measure current (2A/per channel)    |

# DAQ-900

## 20-Channel Universal Multiplexer (Solid State Relay)

- ※ Scanning speed up to 450 channels per second
- ※ 2-wire and 4-wire scanning
- ※ Built-in temperature cold junction reference
- ※ 120 V switching

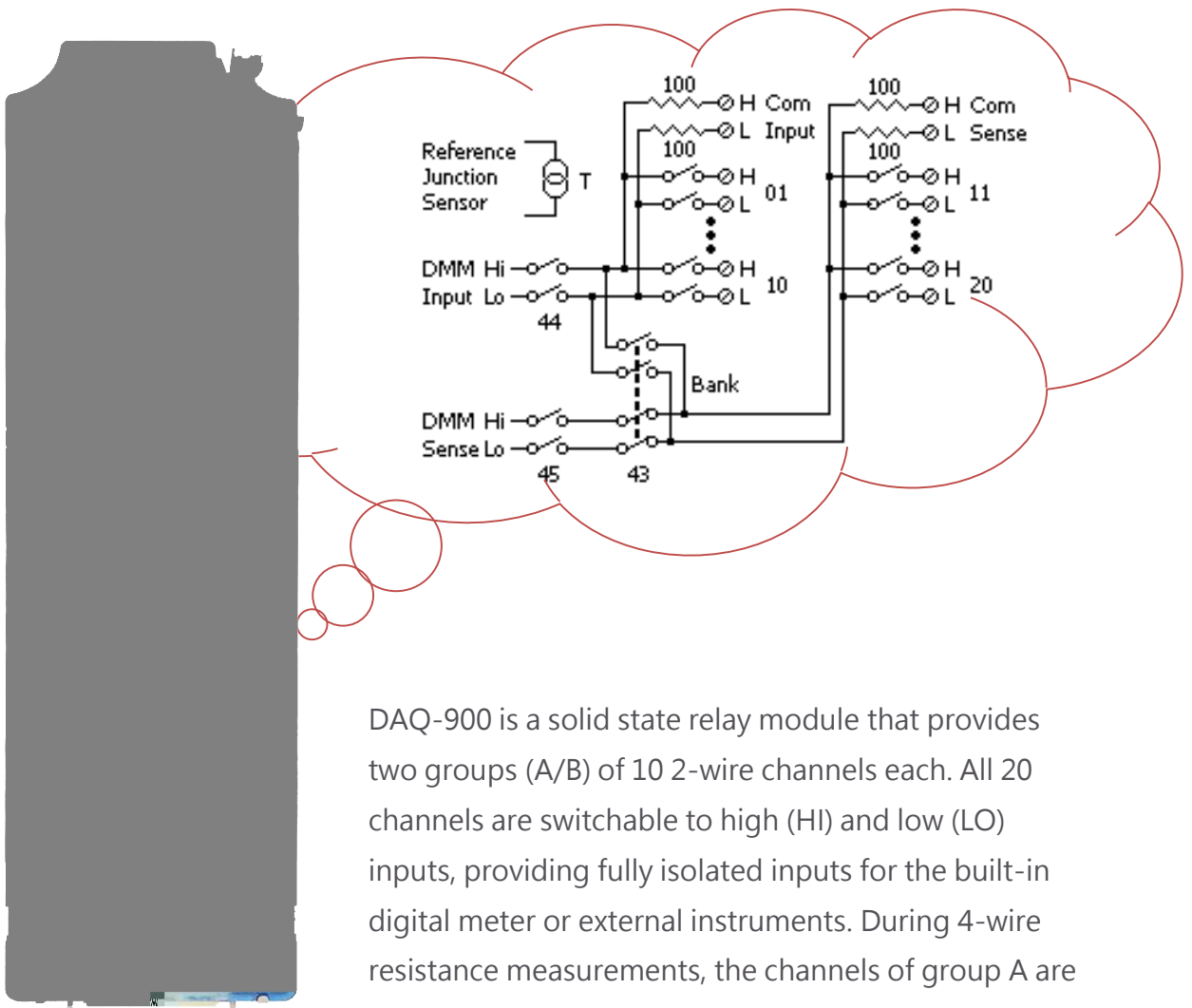

DAQ-900 is a solid state relay module that provides two groups (A/B) of 10 2-wire channels each. All 20 channels are switchable to high (HI) and low (LO) inputs, providing fully isolated inputs for the built-in digital meter or external instruments. During 4-wire resistance measurements, the channels of group A are automatically paired with the channels of group B to provide power and sense connections. The module has a built-in cold junction reference, which can greatly reduce errors caused by thermal gradients when measuring thermocouples

# DAQ-901

## 20+2 Channels Universal Multiplexer (Armature Relay)

- ※ The scanning speed can reach 80 channels per second
- ※ 2-wire and 4-wire scanning
- ※ Built-in temperature cold junction reference
- ※ 300 V switching
- ※ The extra 2 channels can directly measure the current (1A/each channel)

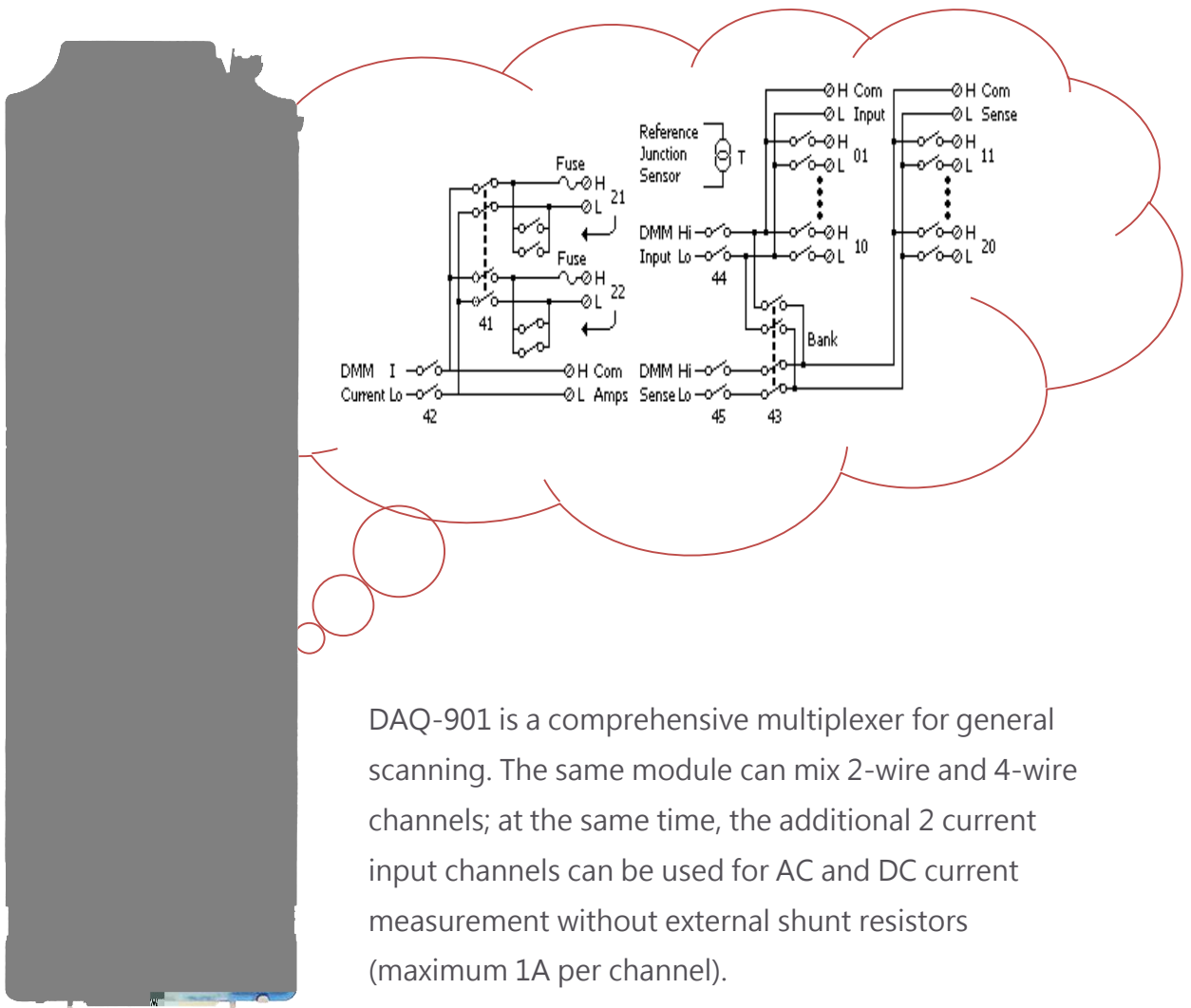

DAQ-901 is a comprehensive multiplexer for general scanning. The same module can mix 2-wire and 4-wire channels; at the same time, the additional 2 current input channels can be used for AC and DC current measurement without external shunt resistors (maximum 1A per channel).

DAQ-901, a total of 22 channels, intensive multi-function switching and a scan rate of up to 80 channels per second, is suitable for various data acquisition applications.

# DAQ-903

## 40-Channel Single-Ended Multiplexer

- ※ The scanning speed can reach 80 channels per second
- ※ Single-wire switching is suitable for common-low applications
- ※ 2-wire scanning (except current)

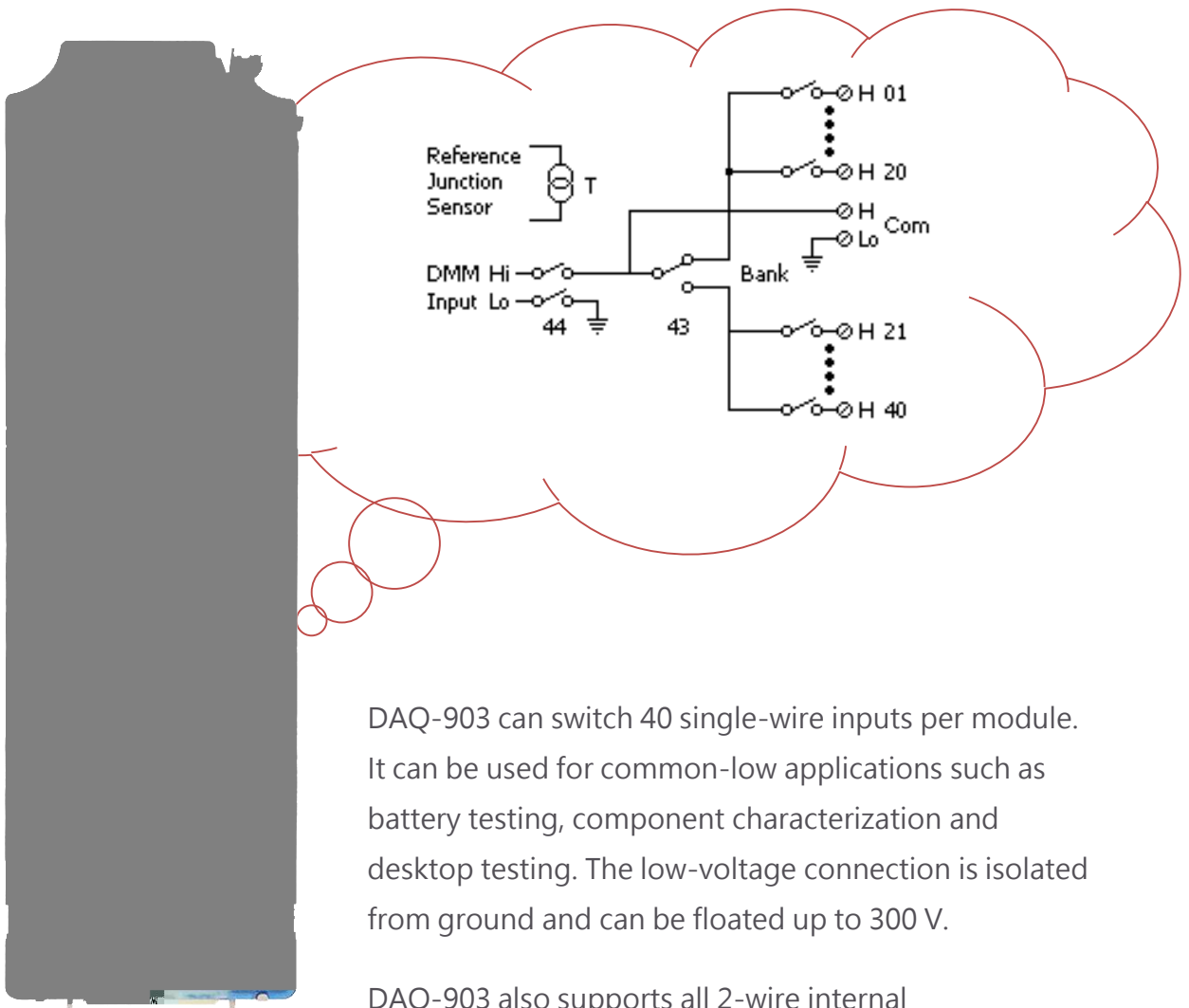

DAQ-903 can switch 40 single-wire inputs per module. It can be used for common-low applications such as battery testing, component characterization and desktop testing. The low-voltage connection is isolated from ground and can be floated up to 300 V.

DAQ-903 also supports all 2-wire internal measurements except current.

# DAQ-904

## 4 x 8 2-Wire Matrix

- ※ The switching speed 3ms
- ※ 32 2-wire intersections
- ※ 300 V, 1A switching
- ※ Up to 96 crosspoints (3 slots)

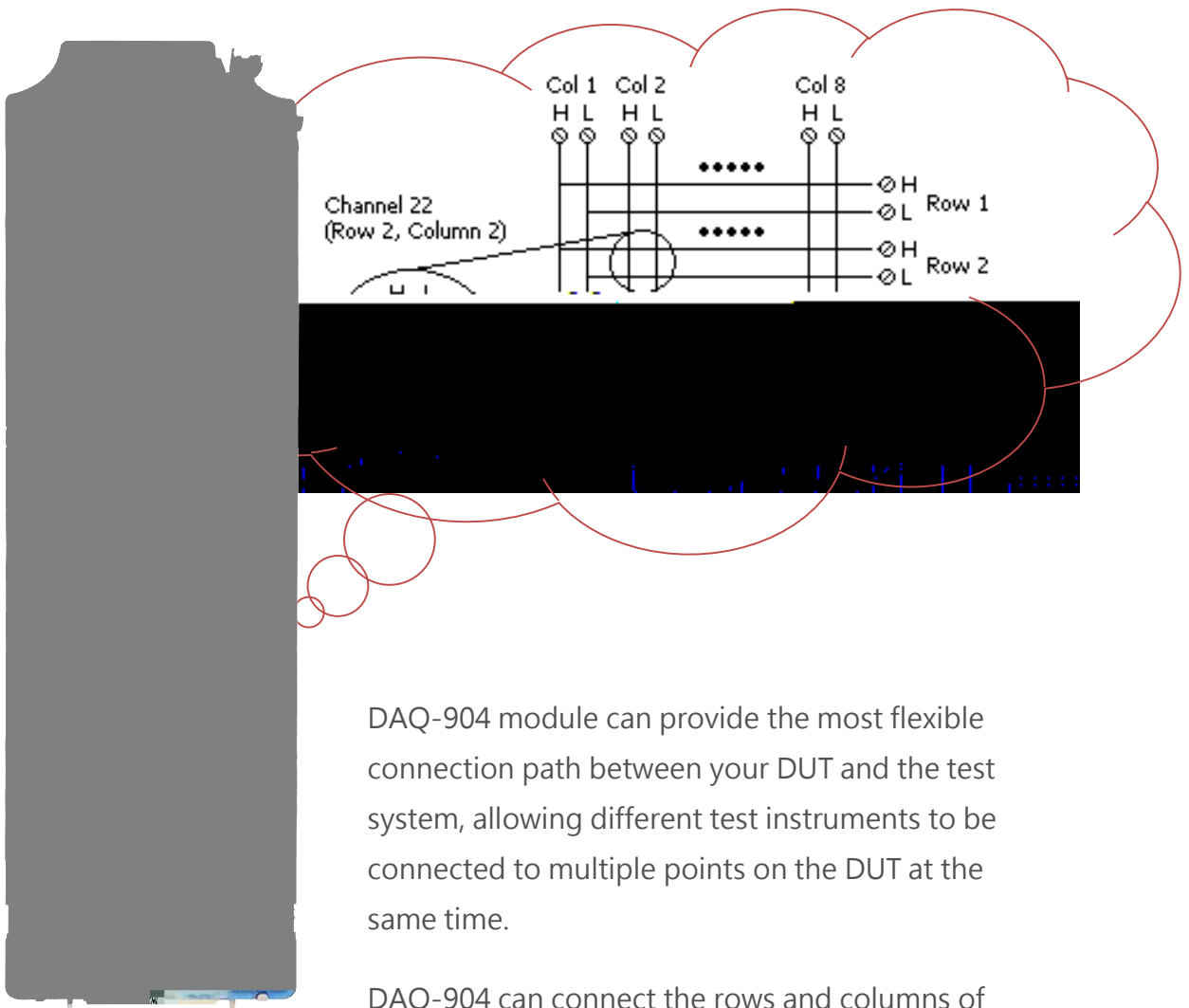

DAQ-904 module can provide the most flexible connection path between your DUT and the test system, allowing different test instruments to be connected to multiple points on the DUT at the same time.

DAQ-904 can connect the rows and columns of multiple modules to build larger matrices, such as 8 x 8, 4 x 16...etc. Up to 96 crosspoints can be built in a single instrument.



# DAQ-909

## 8+2 Channels High Voltage High Current Multiplexer

- ※ The scanning speed reaches 60 channels per second
- ※ DC voltage 600V, current 2A
- ※ 2-wire and 4-wire scanning
- ※ Additional 2 channels can directly measure current (2A/each channel)

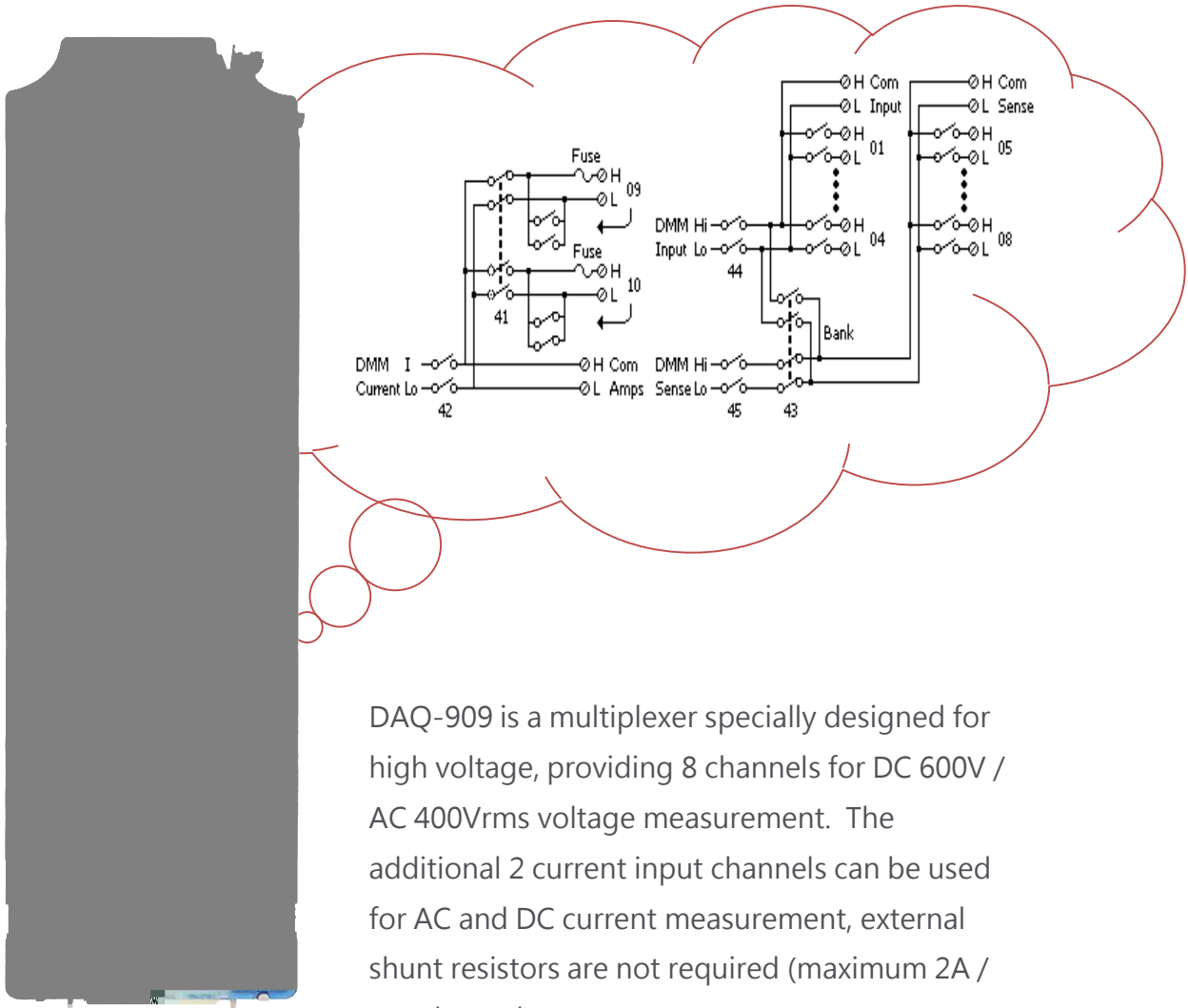

DAQ-909 is a multiplexer specially designed for high voltage, providing 8 channels for DC 600V / AC 400Vrms voltage measurement. The additional 2 current input channels can be used for AC and DC current measurement, external shunt resistors are not required (maximum 2A / per channel).

# Modules Characteristics

A single mainframe can insert up to three modules (in any combinations).

The built-in digital multimeters of DAQ-9600, except DAQ-904, can be connected and used via DAQ-900, DAQ-901, DAQ-903 and DAQ-909 multiplexers.

	Multiplexer	Multiplexer	Multiplexer	Matrix	Multiplexer
	DAQ-900	DAQ-901	DAQ-903	DAQ-904	DAQ-909
CH No.	20	20+2	40	4 x 8	8+2
Speed (Scan)	450 CH/s	80 CH/s	80 CH/s		60 CH/s
<b>Internal DMM measurement functions supported</b>					
AC/DC Voltage	√ <sup>2,3</sup>	√	√		√
AC/DC Current		√			√
Freq./Period	√	√	√		√
2Wire Resistance	√ <sup>1</sup>	√	√		√
4Wire Resistance	√ <sup>1</sup>	√			√
Thermocouple	√	√			√
2Wire RTD		√	√		√
4Wire RTD		√			√
Transistor		√	√		√
<b>Characteristics – typical: Input (DC · AC rms)</b>					
Voltage (V)	120	300	300	300	DC 600 AC 400
Current (A)		1		1	2
<b>Characteristics – typical: Others</b>					
T/C CRJ Accuracy	0.8°C	0.8°C			
Lifetime (No Load)	see <sup>4</sup>	10M	10M	10M	100M
Lifetime (Rated Load)	see <sup>4</sup>	100k	100k	100k	100k

1. For the measurement of 100 Ω and 1 kΩ resistance ranges, it is recommended to use 4-wire resistance. The maximum resistance range of DAQ-900 is 1 MΩ.

2. When measuring AC voltage, the input impedance will decrease with frequency. A source impedance of 5 Ω or less will maintain specification over frequency. A source impedance of 50 Ω or less will maintain specification in the 5 kHz range.

3. For DC voltage measurement, if the integration time is short and the source impedance is high, more stabilization time may be required.

4. The module has an armature backplane and 2-wire/4-wire relays with a life of 100 M cycles (unlimited life cycle within FET Bank)

## Switch Modules

Model Name	Model description	Type	Speed (Scan)	Max volts	Max amps	Comments
DAQ-900	20 ch Multiplexer	2-wire solid state (4-wire selectable)	450	120V		Built-in cold junction reference
DAQ-901	20 ch Multiplexer + 2 current channels	2-wire armature (4-wire selectable)	80	300V	1A	Built-in cold junction reference 2 additional current channels (22 total)
DAQ-903	40 ch Single-Ended Mux	1-wire armature (common low)	80	300V		No four-wire measurements
DAQ-904	4 x 8 Matrix	2-wire armature		300V	1A	
DAQ-909	8 ch Multiplexer + 2 current channels	2-wire armature (4-wire selectable)	60	600Vdc 400Vac	2A	DC high voltage / current channels

## SPECIFICATIONS

DISPLAY	4.3" Color TFT LCD		
SLOT	3		
Sample Rate	10k SPS (max.)		
Internal memory	100k_Sample (nonvolatile)		
Measurement Characteristics			
	Range	Resolution	Accuracy (*)
DC Voltage	100mV to 600V	0.1 $\mu$ V to 1mV	0.0035%
AC Voltage	100mV to 300V	0.1 $\mu$ V to 1mV	0.05%
Resistance	100 $\Omega$ to 1000 M $\Omega$	0.1 m $\Omega$ to 1000 $\Omega$	0.01%
Frequency	3Hz to 300kHz		0.01%
DC Current	1 $\mu$ A to 2A	1pA to 1 $\mu$ A	0.05%
AC Current	100 $\mu$ A to 2A	100pA to 1 $\mu$ A	0.10%
Capacitance	1nF to 100 $\mu$ F	0.0001nF to 0.01 $\mu$ F	2%
Temperature (TC)	-200 $^{\circ}$ C to 1820 $^{\circ}$ C	0.002 $^{\circ}$ C to 0.01 $^{\circ}$ C	0.2 $^{\circ}$ C
Temperature (TM)	-80 $^{\circ}$ C to 150 $^{\circ}$ C	0.01 $^{\circ}$ C	0.01 $^{\circ}$ C
Temperature (RTD)	-200 $^{\circ}$ C to 600 $^{\circ}$ C	0.002 $^{\circ}$ C	0.06 $^{\circ}$ C
General Information			
USB storage	Available		
Interface	Digital I/O, LAN and USB host/device		
Optional Interface	mini GPIB		
Power Source	AC 100V/120V/220V/240V $\pm$ 10%		
Dimensions & Weight	267(W) x 107(H) x 380 (D) mm; Approx. 4.5kg		

\* : The accuracy is based on the value measured with DAQ-901.

Specifications subject to change without notice.

Global Headquarters

**GOOD WILL INSTRUMENT CO., LTD.**

1000, Jijiang Road, Tucheng Dist., New Taipei City 236, Taiwan  
T +886-2-2268-0389 F +886-2-2268-0639  
E-mail: marketing@goodwill.com.tw

China Subsidiary

**GOOD WILL INSTRUMENT (SUZHOU) CO., LTD.**

No. 691 Zhuyuan Road, Suzhou, Jiangsu, 215011, China

U.S.A. Subsidiary

**INSTEK AMERICA CORP.**

5198 Brooks Street Montclair, CA 91763, U.S.A.  
T +1-909-399-3535 F +1-909-399-0819

Japan Subsidiary

**TEXIO TECHNOLOGY CORPORATION.**

7F Towa Fudosan Shin Yokohama Bldg., 2-18-13 Shin  
Yokohama, Kohoku-ku, Yokohama, Kanagawa